

500 Watt Wind Turbine
Model UP500A
Installation Instructions
Revision Date June 15th, 2009

******Please read this manual before use!******



[The Other Power Company.ca](http://TheOtherPowerCompany.ca)

1-877-4-WND-PWR

Support@TheOtherPowerCompany.ca

Basic Use

This wind turbine system is designed to work with the HD500W controller to charge a 24 volt DC battery system. DC power can be used directly from the batteries or it can be used to power an inverter such as our model SM500-241 to run power tools and small appliances.

Technical specifications

Wind Rotor diameter (3 blade)	2.5 meters (8.2 feet)
Operating Voltage	DC24V
Blade Material	Fiberglass Reinforced Plastic
Rated Power	500 Watts
Rated Wind Speed	10 meters/second (22.4 mph)
Startup Wind Speed	3 meters/second (6.71 mph)
Working Wind Speed Range	3 to 25 meters/second (6.71 mph – 55.9 mph)
Maximum Wind Speed	40 meters/second (77.8 mph)
Speed Control	Yaw + Electromagnetic Brake
Shutdown Mode	Manual Brake
Power Generation Method	Three-phase AC via permanent magnet alternator

Installation Preparation

1. Purchase suitable battery pack. Two 12V 150aH deep cycle batteries are recommended. Batteries such as the Interstate U1450 or U1850 are suitable.
2. Verify the contents of your wind turbine shipment to ensure there are no missing parts. Refer to the manifest annex for a complete list of what you should have. Contact your sales representative to correct any deficiencies before you begin the installation.
3. Choose a site to install the turbine. It is important to ensure that there are no overhead power lines or other obstructions. Make sure that the turbine is located no more than 30 meters (approx. 100 feet) from the charge controller and battery system. This is to maximise the performance of your turbine system. Refer to figure 1 as a guide to the minimum space required for installation of guy lines and anchor points.
4. As a safety precaution, it is recommended that the turbine be installed no closer than 3 blade diameters (in this case, 7.5 meters or 24.6 feet) from any building or object. This is because during the winter ice buildup can fall within this distance as it is shed from your turbine and tower system.

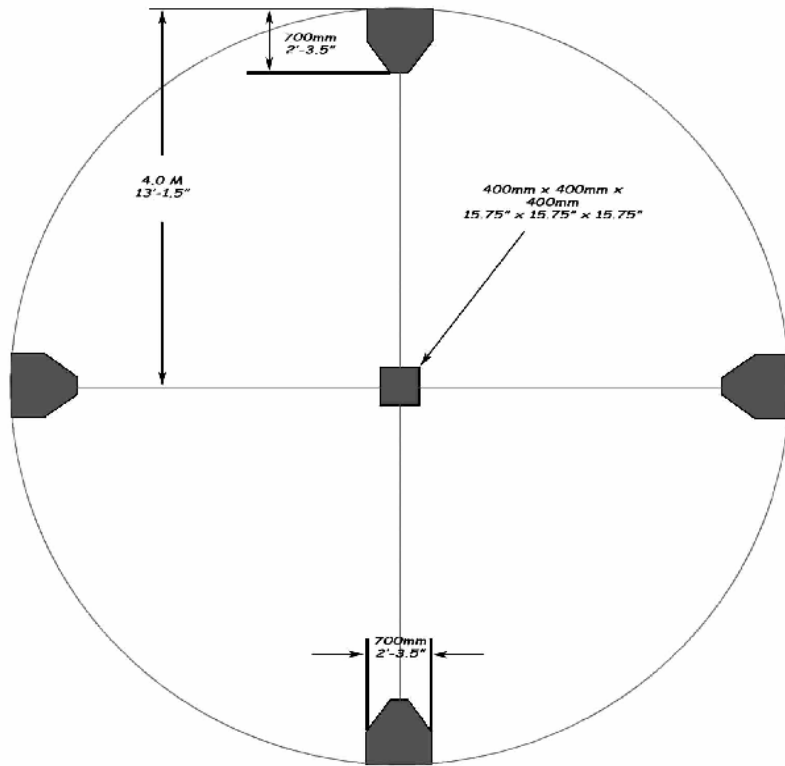

Figure 1

Construction of base and anchor points

1. Dig a hole where you plan to install your base. The size of the base should be 40X40X40cm (15.75" x 15.75" x 15.75").
2. Dig four triangular holes (each side is 70cm or 27 inches) with a depth of 70 cm (27 inches) symmetrical 4.0 meters (13 feet) from the central hole in four directions. See figure 1 for proper layout.
3. Fix the 4-foundation bolts onto the base plate with the M16 nuts. (The threads should be approximately 15mm (½ inch) out of nut) Refer to figure 2.

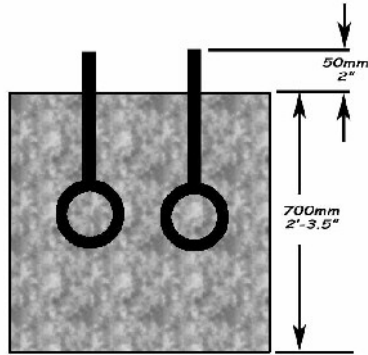

Figure 2

4. Put the Base plate in the center and orient it so that the flat sides each face one of the anchor points. The Base plate should be 4-5cm higher than the ground. Adjust the base plate to ensure that it is level.
5. Add concrete to the base. (mixture ratio is cement : sand : gravel = 1:2:3)
6. Trowel the surface flat to ensure that mounting plate can be placed level on the surface.
7. Dig an anchor pit as shown in Fig 3. These should be 4 meters (13 feet) from the center base arranged so that they are 90 degrees apart.
8. Arrange the anchor in the pit as shown in Fig 3. It should be 60 degrees off of horizontal, as shown in figure 3.

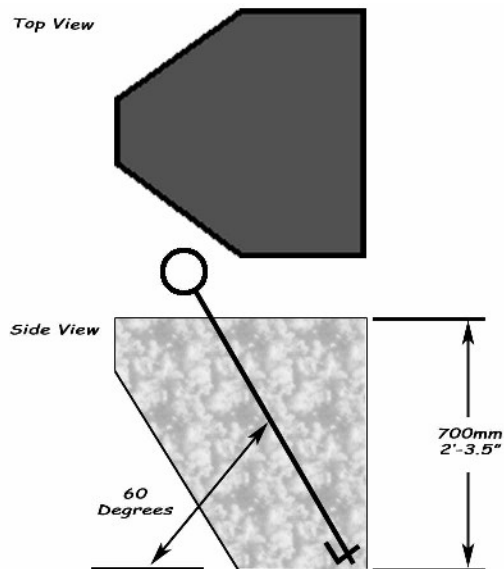

Figure 3

9. Fill the pit with concrete of the same ratio as step 5.
10. Repeat steps 7 to 9 for the 3 remaining anchor points.
11. Cover your cement work so that rain does not pit the surface. This is most important with the center pylon as you will require a flat surface. Rain water can create an uneven surface that is difficult to level the base plate on!
12. WAIT. Follow the directions on the cement or use the rough drying time of 100 hours. That's just about 4 days. It is important that the cement is cured before applying force to it. Unlike footings for decks and patios, the anchor points must cure properly before use to ensure that the tower will not fail in high winds.

Construction of the tower and turbine assembly

1. In a very low wind condition (less than 2 meters/second or 4.5 mph) you may begin the installation. Attempting to install a turbine in higher wind speeds can be dangerous to the installers and could cause serious damage to the turbine.
2. Using the M16 nuts and washers, secure the base to the center pylon. Ensure that the plate is level before continuing. If it is not, shim with washers to ensure that it is.
3. Lay out the 3 sections of the support tower.
4. Connect the bottom section of the tower to the base pivot plate using the bolt provided.
5. Bolt together each section of tower with the bolt heads at the top and the nuts pointing down the tower. Ensure that all bolts are tight before moving to the next step.
6. Install the connection wire through the tower pipe and connect to the terminal block at the top of the tower.
7. Using a saw horse or other cradle, support the top of the tower up off of the ground so that the generator can be installed.
8. Splice the 3 wires from the generator to the wire running up the tower. Ensure that the splice is well insulated and is capable of insulating up to 600 volts. The wire order does not matter.
9. Slide the generator mount on to the tower section. Secure with the bolt provided.
10. Assemble the rotor section. This should be done on a flat surface away from the tower construction following figure 4. All of the parts are marked with their proper locations. Tighten the bolts to 40-45 Nm (29.5-33.2 foot-pounds) using a torque wrench. Do not install the nose cone at this point.

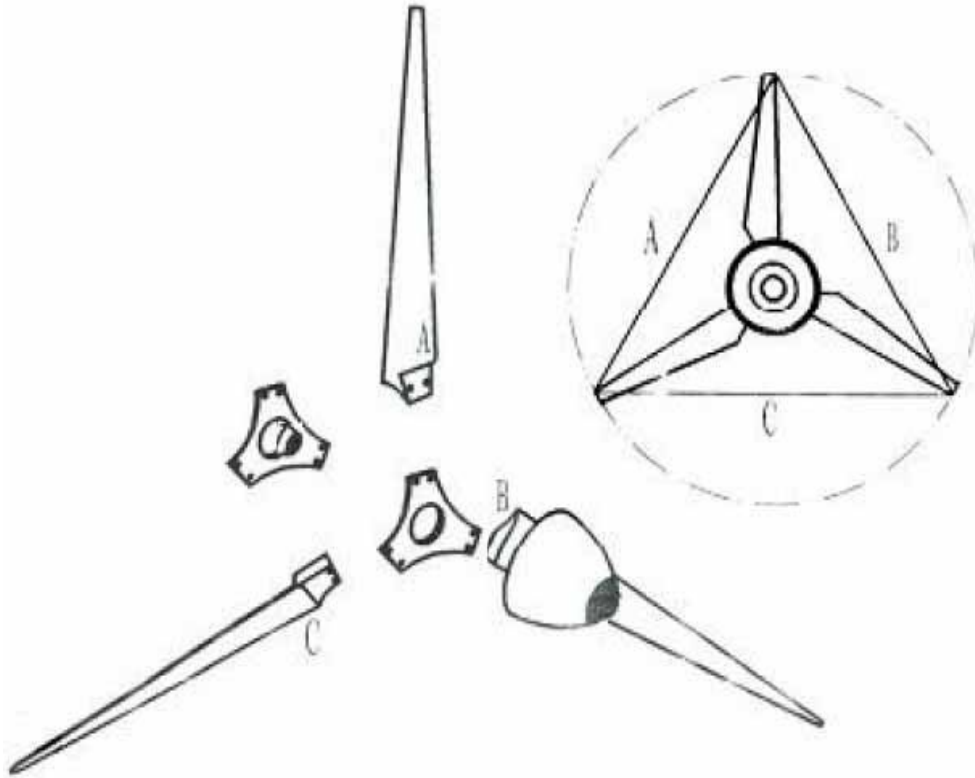

Figure 4

11. Assemble the tail section using the 10 bolts provided.
12. Attach the tail section and connect the tail return spring as shown in Figure 5.



Figure 5

13. Turn the generator so that the drive shaft is pointing up and the tail is turned to approximately 90 degrees. Attach the rotor assembly to the generator using the crown nut provided. Tighten until the nut is snug. Insert the locking pin to secure the nut in place. Bend over one end of the pin so that the pin can not come loose. Install the nose cone.

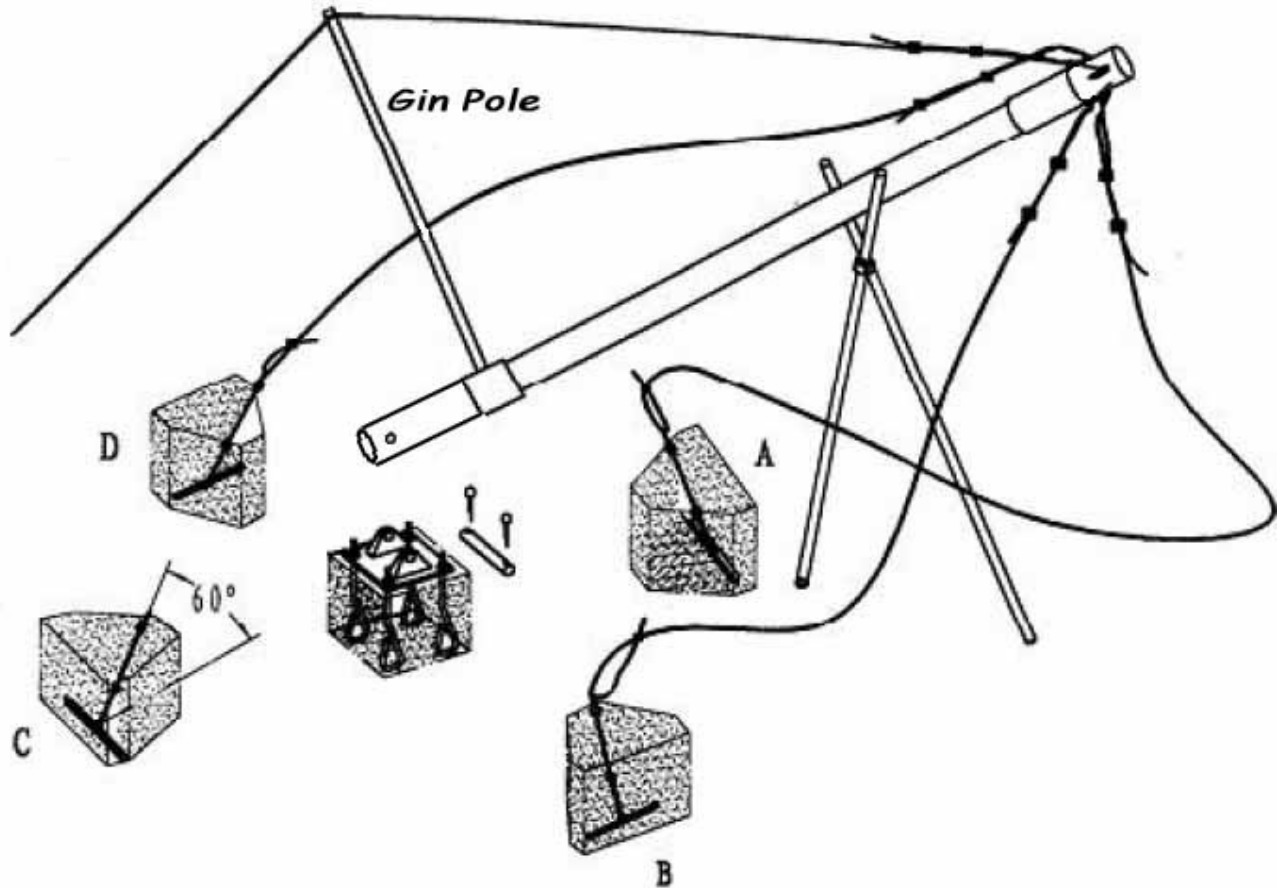

Figure 6

14. Adjust the guy lines to the correct length. The wires should be assembled as shown in Fig. 6. Attach all top guy lines to the anchor points on the tower. Only attach 3 of the guy lines (A, B and D) to the anchor points. The fourth (C) will be used to raise the tower. For safety, ensure that the U bolts are installed as shown in figure 7. Wrap the dead end of the cable in electrical tape to reduce the chance of being cut by metal slivers from the cable.

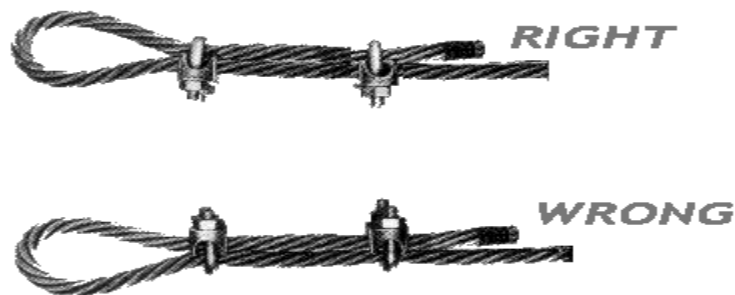

Figure 7

IMPORTANT!

Before continuing the tower installation, the electrical connections must be made to ensure your safety. A wind turbine that is allowed to rotate without a load can generate unsafe voltages that can be harmful or lethal.

Electrical connection

Assuming that your wire has been run in a trench to where you intend to permanently install your controller, follow the directions below to complete your turbine electrical installation.

1. Mount the dump load controller on a non-flammable surface as you would an electric heater. It is recommended that it is mounted against at least 1 layer of 1/2" drywall that is mounted to a plywood backing board. The dump load acts as a load in the event that your batteries are fully charged and there is still enough wind to generate electricity. In this circumstance, power is diverted to the dump load until it is needed by the battery pack. Ensure that there are no wires or flammable substances touching the dump load.
2. Mount the controller in such a way as to permit access to the wires at the back when needed. Ensure the manual brake is set to 'ON'.
3. Connect a section of the wire provided from the 3 ports marked 'Dump Load' to the 3 screw terminals on the dump load.
4. Connect the 3 wires from the wind turbine to the 3 connections on the controller marked 'Wind'.
5. Place the batteries in a ventilated safe area then connect the 2 batteries in series to form a 24 volt chain. Connect the + and – from the chain to the controller ensuring the proper polarity is maintained.
6. Using the ground connection provided, connect your controller and dump load to a suitable ground connection near the controller.

Warning

The following section deals with steel cable under tension. It is very important that the installer is aware of the dangers of cable under tension. Ensure all cable connections are tight before continuing!

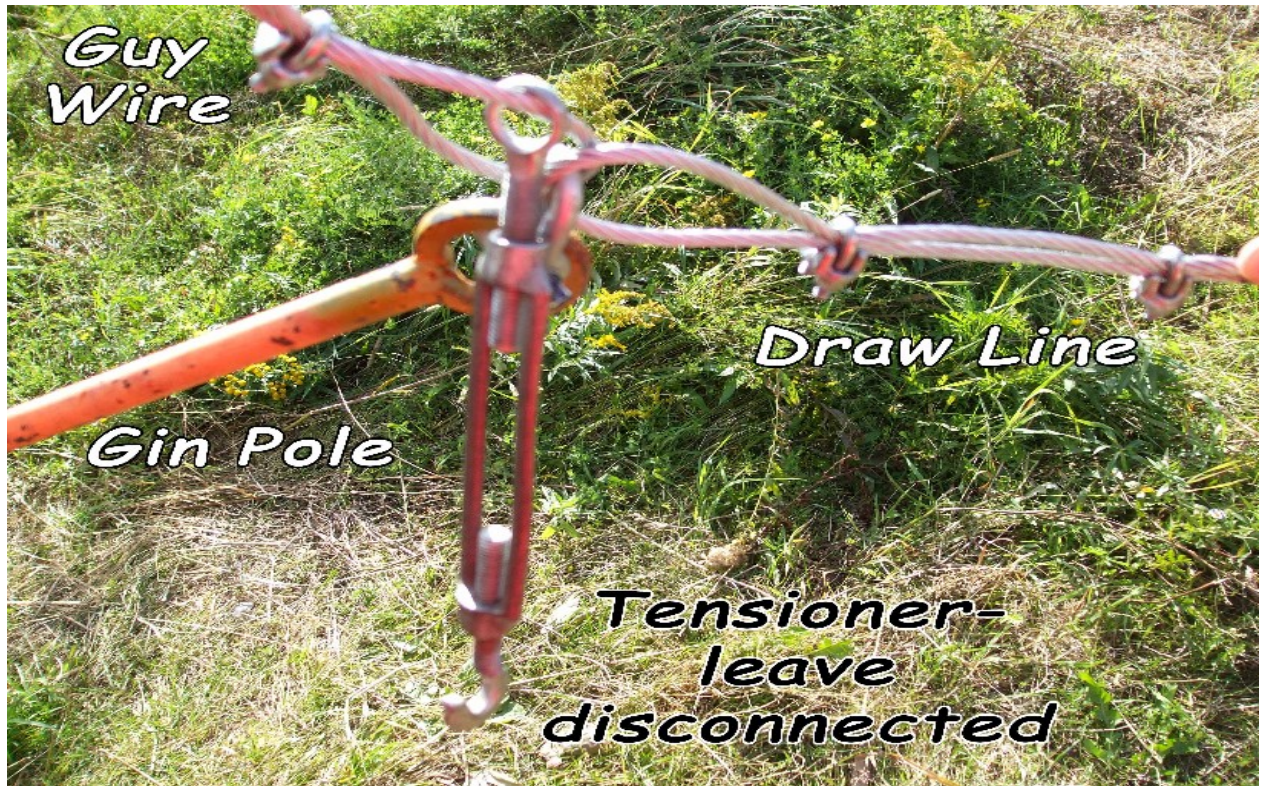

Figure 8

Erecting the tower

1. Attach the dead man to guy wire C and then to the tower base as shown in figure 8. Ensure that the cable is secured and the cable tensioner is adjusted to its maximum safe extension.
2. Thread the take up wire through the anchor point C and connect it to a winch or tow vehicle.
3. Take up the slack with the tow vehicle slowly. Have a member of your team guide the generator tail and blades off of the support cradle so that it does not drag on the ground. When it has cleared the ground they should evacuate to a safe distance.
4. When the tower is vertical, approach anchor point C and connect the tensioner directly to the anchor point.
5. Slowly release tension from the tow vehicle or winch.
6. Adjust all 4 tensioners so that the tower stands vertically. All guy wires should be tight.

Grounding the tower

Although a grounding kit is not included, it is a good practice to ground the tower to protect your electronics from lightening strikes. Using an 8' ground rod driven in the ground 1M (3') from the concrete base, attach a wire (minimum #8) to the ground rod and one of the bolts of the base plate using an additional nut and washers. The grounding rod and wire can be buried up to the base pylon.

System startup

With all electrical connections in place, release the manual brake on the turbine. Observe the turbine for any vibration or abnormal sounds. Investigate any vibrations immediately.

Stopping the turbine

Apply the manual brake and the turbine will stop. It is not recommended to stop the turbine while the wind is blowing unless it is an emergency.

Maintenance

Like any machinery, wind turbines require periodic maintenance. Your turbine system was designed to be as maintenance free as possible, but it is recommended that the turbine be taken down once per year and inspected. The following annual maintenance is recommended.

Stop turbine before any maintenance is carried out!

1. Visual inspection of the blades and all surfaces for defects. If any surface is found to have pits or other imperfections they should be made smooth.
2. Oil the tail return spring. If the spring is found to have rusted or lost its elasticity it should be replaced.
3. Application of a wax agent to the blade surfaces such as F21 or Armour All can be applied at this time. This will decrease the likelihood of ice sticking to the blades in the winter.
4. Every 2 years the tower and surfaces should be inspected for rust or corrosion. In coastal locations this should be carried out every year to prevent damage from salt.
5. Every 5 years the bearings should be inspected and greased with lithium grease. This will prolong the life of the generator.

Battery maintenance is specific to each battery manufacturer. Refer to the manual from your battery package for information on required service tasks.

A note on wind turbines and high winds

In the Atlantic provinces of Canada it is a common occurrence to have high winds. In most cases this will not adversely affect your turbine. The major danger from extreme wind is the debris that can be picked up. If anything strikes a spinning turbine the damage can be total. Be sure to apply the brake and wait out any extreme wind conditions.

Any questions or comments can be submitted via our forums at www.TheOtherPowerCompany.ca



**Unplugged
Power
Systems**

The Other Power Company.ca

support@TheOtherPowerCompany.ca